

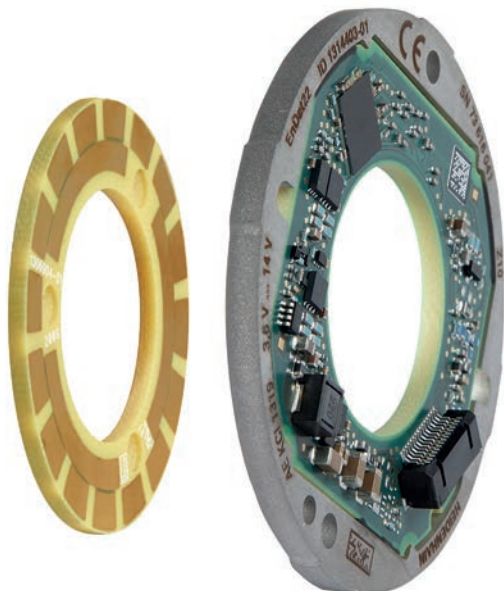

# HEIDENHAIN



Product Information

**KCI 1319**

**KBI 1335**

Absolute Inductive  
Rotary Encoders without  
Integral Bearing

# KCI 1319, KBI 1335

Rotary encoders for absolute position values

- Robust inductive scanning principle
- Consisting of an AE scanning unit and a rotor unit

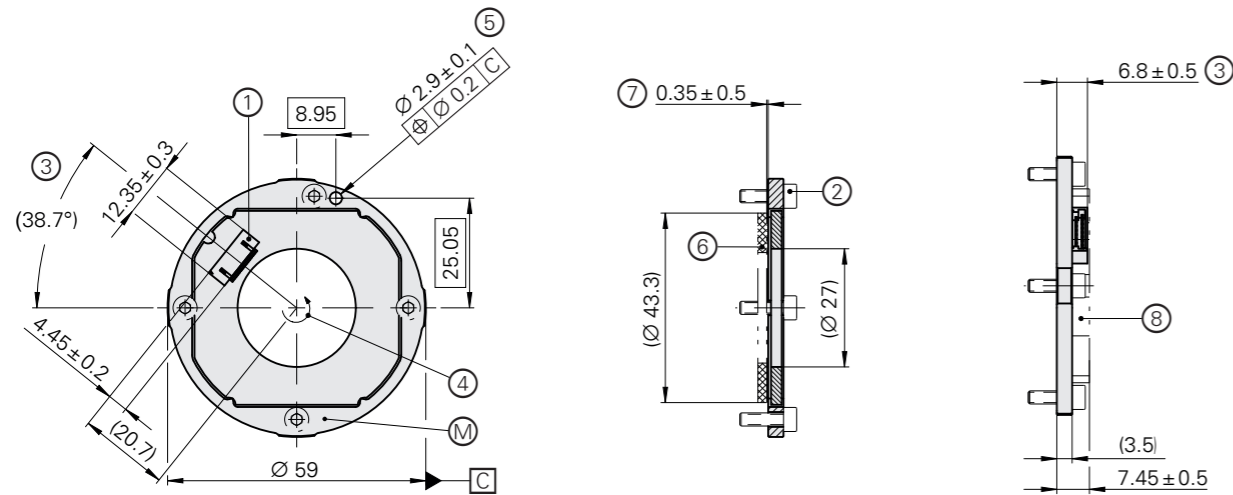

## Required mating dimensions for AE KxI 13xx

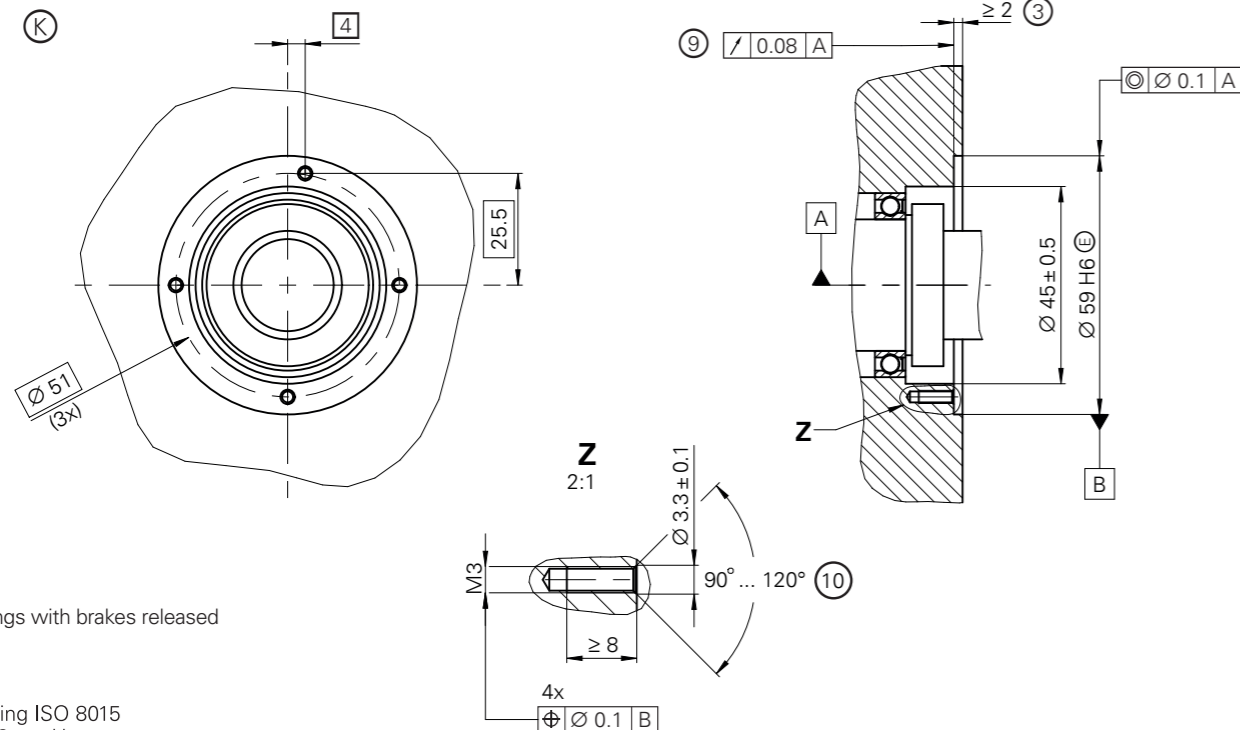

All drawings with brakes released

mm  
  
 Tolerancing ISO 8015  
 ISO 2768 - m H  
 < 6 mm: ±0.2 mm

- ▣ = Bearing of mating shaft
- ⊙ = Required mating dimensions
- ⊙ = Measuring point for operating temperature
- 1 = 15-pin PCB connector
- 2 = M3x10 cylinder head screw (4x)
- 3 = Ensure space for cable
- 4 = Direction of shaft rotation for ascending position values
- 5 = Additional and optional orientation possibility
- 6 = TK/TKN, separate, with different versions possible; for mounting, see the respective dimension drawing
- 7 = Mounting clearance between the circular scale surface and the flange surface; compensation of mounting tolerances and thermal expansion; dynamic motion permitted over entire range (with use of ATS software for mounting inspection, the display value for the mounting clearance is shown as 1 mm)
- 8 = Ensure space for electronics; see also the mating dimensions model
- 9 = Flange surface; ensure full-surface contact!
- 10 = Chamfer at start of thread is mandatory for material bonding anti-rotation lock

		Total height	Tolerance
AE KxI 13xx	Circular scale (screw-fastened version)	9.8	±1.2
	Disk/hub assembly (press-fitted version)	14.6	

## Rotor fastening via three axial countersunk head screws

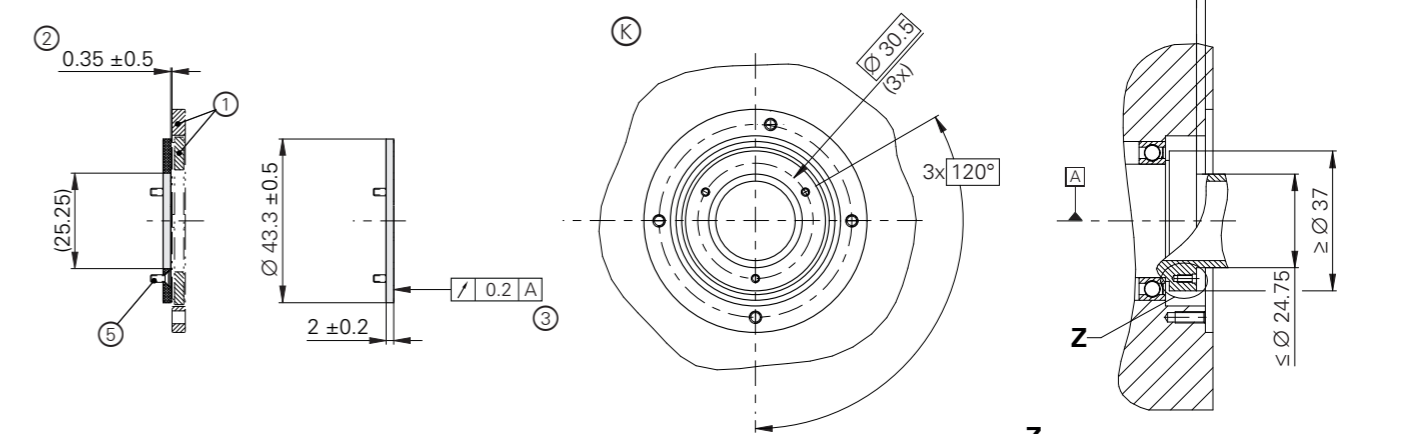

## Rotor fastening via press-fitted hub

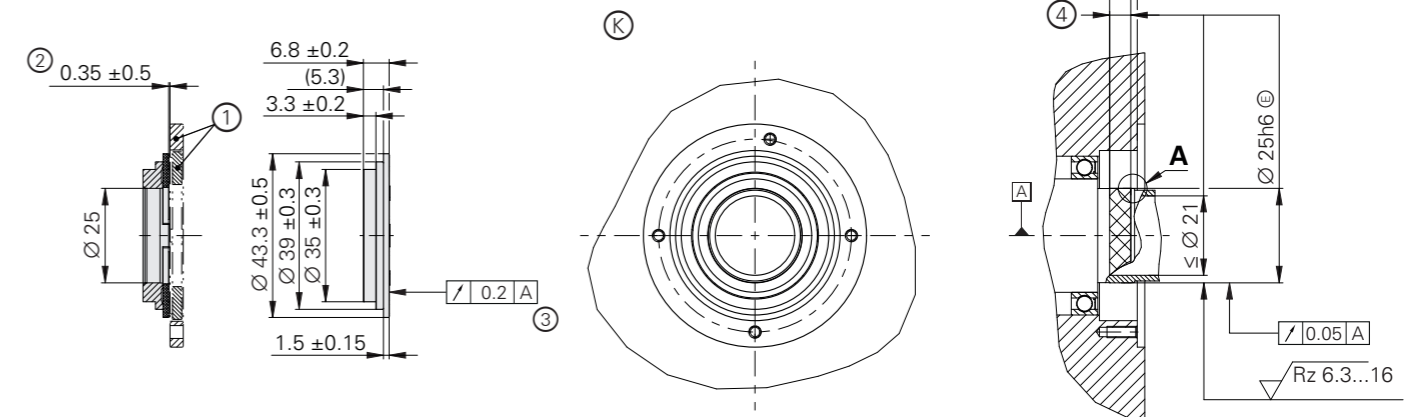

- ▣ = Bearing of mating shaft
- ⊙ = Required mating dimensions
- 1 = AE, separate, with different versions possible (KCI 1319/KBI 1335)
- 2 = Mounting clearance between the circular scale surface and the AE flange surface; compensation of mounting tolerances and thermal expansion; dynamic motion permitted over entire range
- 3 = On the fine track (Ø 35.5 mm to Ø 42.4 mm) after screw-fastening/press-fitting
- 4 = For press-fitting parameters, see the Mounting Instructions
- 5 = Countersunk head screw: M2x6 ISO 14581-A2-70, protrusion of screw head not permitted
- 6 = Distance between AE flange surface and circular scale surface
- 7 = Circular scale surface
- 8 = Use material bonding anti-rotation lock (at least medium strength)

Specifications	KCI 1319 singletum	KBI 1335 multitum
<b>Interface</b>	EnDat 2.2	
Ordering designation	EnDat22	
Position values per revolution	524288 (19 bits)	
Revolutions	–	65536 (16 bits)
Calculation time $t_{cal}$ Clock frequency	$\leq 5 \mu s$ $\leq 16 \text{ MHz}$	
System accuracy	$\pm 90''$	
<b>Electrical connection</b>	15-pin PCB connector (with connection for external temperature sensor)	
Cable length	$\leq 100 \text{ m}$ (see the EnDat description in the <i>Interfaces of HEIDENHAIN Encoders</i> brochure)	
Supply voltage	DC 3.6 V to 14 V	<i>Rotary encoder</i> $U_P$ : DC 3.6 V to 14 V <i>Backup battery</i> $U_{Bat}$ : DC 3.6 V to 5.25 V
Power consumption <sup>1)</sup> (max.)	<i>At 3.6 V</i> : $\leq 650 \text{ mW}$ <i>At 14 V</i> : $\leq 700 \text{ mW}$	
Current consumption (typical)	<i>At 5 V</i> : 95 mA (without load)	<i>Normal operation at 5 V</i> : 95 mA (without load) <i>Backup battery</i> : 200 $\mu A$ (rotating shaft) <sup>2)</sup> 20 $\mu A$ (at standstill)
<b>Part number</b>	AE KCI 1319 scanning head 1314403-01 Circular scale (screw-fastened version) 1314410-01 Disk/hub assembly (press-fitted version) 1314409-01	AE KBI 1335 scanning head 1314404-01 Circular scale (screw-fastened version) 1314410-01 Disk/hub assembly (press-fitted version) 1314409-01

<sup>1)</sup> See *General electrical information* in the *Interfaces of HEIDENHAIN Encoders* brochure or at [www.heidenhain.com](http://www.heidenhain.com)

<sup>2)</sup> At  $T = 25 \text{ }^\circ\text{C}$ ;  $U_{Bat} = 3.6 \text{ V}$

Specifications	KCI 1319 singletum	KBI 1335 multitum
<b>Rotor*</b>	Circular scale with inside hub diameter of 25 mm (press-fitted version) Circular scale with circular hole pattern diameter of 30.5 mm (screw-fastened version)	
Shaft speed	$\leq 10000 \text{ rpm}$	
Moment of inertia	<i>Disk/hub assembly</i> : $6.3 \cdot 10^{-6} \text{ kgm}^2$ <i>Circular scale</i> : $1.16 \cdot 10^{-6} \text{ kgm}^2$	
Angular acceleration of rotor <sup>1)</sup>	$\leq 1 \cdot 10^5 \text{ rad/s}^2$	
Axial motion of measured shaft	$\leq \pm 0.5 \text{ mm}$	
<b>Vibration</b> 55 Hz to 2000 Hz <sup>2)</sup> <b>Shock</b> 6 ms	<i>Stator</i> : $\leq 400 \text{ m/s}^2$ ; <i>rotor</i> : $\leq 600 \text{ m/s}^2$ (EN 60068-2-6) $\leq 2000 \text{ m/s}^2$ (EN 60068-2-27)	
<b>Operating temperature</b>	$-40 \text{ }^\circ\text{C}$ to $115 \text{ }^\circ\text{C}$	
<b>Trigger threshold</b> of temperature exceedance error message	$130 \text{ }^\circ\text{C}$ (measuring accuracy of the internal temperature sensor: $\pm 1 \text{ K}$ )	
<b>Relative humidity</b>	$\leq 93 \%$ ( $40 \text{ }^\circ\text{C}/21 \text{ d}$ as per EN 60068-2-78), condensation excluded	
<b>Protection rating</b> EN 60529	IP00	
<b>Mass</b>	AE + TK $\approx 0.03 \text{ kg}$ AE + TKN $\approx 0.05 \text{ kg}$	

\* Please select when ordering

<sup>1)</sup> With multiturn functionality in normal operation; maximum permissible acceleration in backup-battery mode upon request

<sup>2)</sup> 10 Hz to 55 Hz, 4.9 mm constant peak to peak

# Mounting

The KCI 1319/KBI 1335 is mounted either via screw-fastening of the circular scale or through press-fitting of the disk/hub assembly and mounting of the scanning unit. The disk/hub assembly is thereby either press-fitted onto the shaft, or the circular scale is screw-fastened to the given shaft with three screws. The scanning unit is aligned and mounted via four holes on the customer's mounting surface.

The press-fitting process may be performed only once for each disk/hub assembly. For the press-fit, comply with the material properties and conditions for the mating surface stated for proper use in the relevant documents. These requirements must be followed, even when new disk/hub

assemblies are press-fitted onto customer shafts that have already been used. Once the lower limit of the press-fit force has been exceeded, the press-fit force being applied must remain within the specified range for the rest of the procedure until the end position is reached.

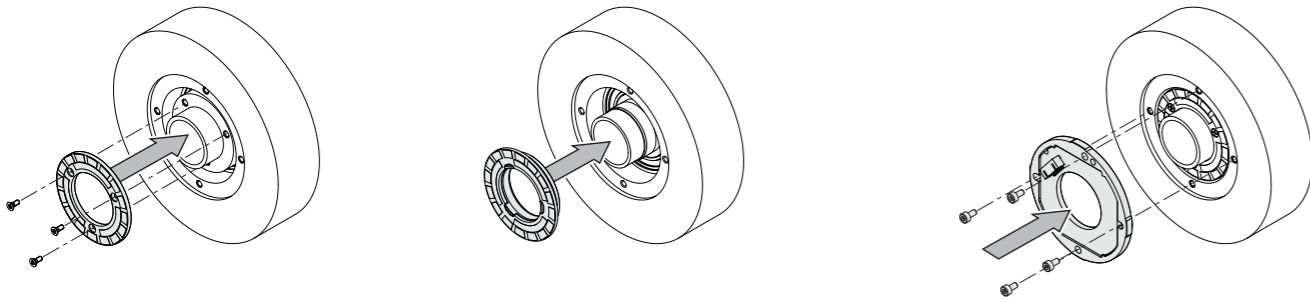

The following material properties and conditions must be complied with for the customer-side mounting design:

	Mating stator	Mating shaft
Material	Aluminum	Steel
Tensile strength $R_m$	$\geq 220 \text{ N/mm}^2$	$\geq 600 \text{ N/mm}^2$
Yield strength $R_{p0.2}$ or yield point $R_e$	–	$\geq 400 \text{ N/mm}^2$
Shear strength $\tau_m$	$130 \text{ N/mm}^2$	$\geq 390 \text{ N/mm}^2$
Interface pressure $P_G$	$\geq 250 \text{ N/mm}^2$	$\geq 660 \text{ N/mm}^2$
Modulus of elasticity E (at 20 °C)	$70 \text{ kN/mm}^2$ to $75 \text{ kN/mm}^2$	$200 \text{ kN/mm}^2$ to $215 \text{ kN/mm}^2$
Coefficient of thermal expansion $\alpha_{\text{therm}}$ (at 20 °C)	$\leq 25 \cdot 10^{-6} \text{ K}^{-1}$	<i>Screw-fastened version:</i> $10 \cdot 10^{-6} \text{ K}^{-1}$ to $17 \cdot 10^{-6} \text{ K}^{-1}$  <i>Press-fitted version:</i> $10 \cdot 10^{-6} \text{ K}^{-1}$ to $12 \cdot 10^{-6} \text{ K}^{-1}$
Surface roughness $R_z$	$\leq 16 \mu\text{m}$	
Friction values	Mounting surfaces must be clean and free of grease. Use screws and washers from HEIDENHAIN in their condition as delivered.	
Tightening procedure	Use a signal-emitting torque wrench as per DIN EN ISO 6789, with an accuracy of $\pm 6 \%$	
Mounting temperature	15 °C to 35 °C	

## Mounting accessories

### Screws

Screws (fastening screws) are not included in delivery; the M3x10 screw with material bonding anti-rotation lock can be ordered separately.

KCI 1319 KBI 1335	Screws		Quantity
Screw for fastening the scanning unit	ISO 4762-M3x10-8.8-MKL <sup>1)</sup>	ID 202264-87	10 or 100
Fastening screw for circular scale	ISO 14581-M2x6-A2-70 <sup>2)</sup>	–	–

<sup>1)</sup> With coating for material bonding anti-rotation lock (for information on use, see the *Encoders for Servo Drives* brochure)

<sup>2)</sup> Without anti-rotation lock; use at least a medium-strength material bonding anti-rotation lock

### Mounting aid

To avoid damage to the cable, use the mounting aid to connect and disconnect the cable assembly. Apply pulling force only to the connector of the cable assembly and not to the wires.

ID 1075573-01

**For more mounting information and mounting aids, see the Mounting Instructions and the *Encoders for Servo Drives* brochure. The mounting quality can be inspected with the PWM 21 and the ATS software (see Document 1082415).**

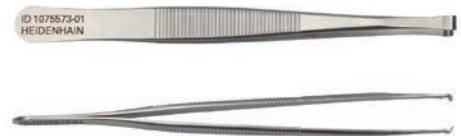

# Electrical connection

## Cables

<b>Output cables inside the motor housing</b> with TPE single wires (8 × 0.16 mm <sup>2</sup> ) and net sleeve without shield		
<b>Output cable</b> with 15-pin PCB connector and 8-pin M12 straight flange socket (male) with TPE single wires for temperature sensor (2 × 0.16 mm <sup>2</sup> )		ID 1119952-xx
<b>Output cable</b> with 15-pin PCB connector and 8-pin M12 straight flange socket (male)		ID 804201-xx
<b>Output cable</b> with 15-pin PCB connector and TPE single wires for temperature sensor (2 × 0.16 mm <sup>2</sup> ), and stripped cable end		ID 1119958-xx <sup>1)</sup>
<b>Output cable inside the motor housing</b> with TPE single wires (8 × 0.16 mm <sup>2</sup> ) and heat shrink tubing without a shield		
<b>Output cable</b> with 15-pin PCB connector and stripped cable end		ID 640055-xx <sup>1)</sup>
<b>Output cable for HMC 6:</b> Ø 3.7 mm EPG 1 × (4 × 0.06 mm <sup>2</sup> ) + 4 × 0.06 mm <sup>2</sup>		
<b>Output cable</b> with 15-pin PCB connector and contact insert for 6-pin HMC 6 hybrid connecting element (male) with TPE single wires for temperature sensor (2 × 0.16 mm <sup>2</sup> ), with cable clamp for shield connection		ID 1072652-xx

<sup>1)</sup> Connecting element must be suitable for the maximum clock frequency used

### Further information:

For connecting cables and adapter cables, see the *Cables and Connectors* brochure.

## Pin layout for KCI 1319

8-pin M12 coupling or flange socket					15-pin PCB connector					
	Power supply				Serial data transmission				Other signals	
	8	2	5	1	3	4	7	6	/	/
	13	11	14	12	7	8	9	10	5	6
	U <sub>P</sub>	Sensor U <sub>P</sub>	0V	Sensor 0V	DATA	DATA	CLOCK	CLOCK	T+	T-
	Brown/ Green	Blue	White/ Green	White	Gray	Pink	Violet	Yellow	Brown	Green

**Cable shield** connected with housing; **U<sub>P</sub>** = Power supply; **T** = Temperature  
**Sensor:** The sense line is connected in the encoder with the corresponding power line.  
 Vacant pins or wires must not be used!

## Pin layout for KBI 1335

8-pin M12 flange socket					15-pin PCB connector					
	Power supply				Serial data transmission				Other signals	
	13	11	14	12	7	8	9	10	5	6
	8	2	5	1	3	4	7	6	/	/
	U <sub>P</sub>	U <sub>BAT</sub>	0V <sup>1)</sup>	0V <sub>BAT</sub> <sup>1)</sup>	DATA	DATA	CLOCK	CLOCK	T+	T-
	Brown/ Green	Blue	White/ Green	White	Gray	Pink	Violet	Yellow	Brown	Green

**U<sub>P</sub>** = Power supply; **U<sub>BAT</sub>** = External buffer battery (false polarity can result in damage to the encoder)  
 Vacant pins or wires must not be used!

<sup>1)</sup> Connected inside encoder

# HEIDENHAIN

**DR. JOHANNES HEIDENHAIN GmbH**  
 Dr.-Johannes-Heidenhain-Straße 5  
 83301 Traunreut, Germany  
 ☎ +49 8669 31-0  
 📠 +49 8669 32-5061  
 E-mail: info@heidenhain.de

[www.heidenhain.de](http://www.heidenhain.de)

This Product Information document supersedes all previous editions, which thereby become invalid. The basis for ordering from HEIDENHAIN is always the Product Information document edition valid when the order is placed.

### Further information:

Comply with the requirements described in the following documents to ensure correct and intended operation:

- Brochure: *Encoders for Servo Drives* 208922-xx
- Brochure: *Cables and Connectors* 1206103-xx
- Brochure: *Interfaces of HEIDENHAIN Encoders* 1078628-xx
- Mounting Instructions: *AE KCI 1319, KBI 1335* 1335452-xx
- Mounting Instructions: *TK KxI 13xx, TKN KxI 13xx* 1343368-xx